

# SECTION : 5C

## CLUTCH

**CAUTION :** Disconnect the negative battery cable before removing or installing any electrical unit or when a tool or equipment could easily come in contact with exposed electrical terminals. Disconnecting this cable will help prevent personal injury and damage to the vehicle. The ignition must also be in LOCK unless otherwise noted.

### TABLE OF CONTENTS

<b>SPECIFICATIONS</b> .....	5C-1	Clutch Pedal Adjustment .....	5C-7
Fastener Tightening Specifications .....	5C-1	Clutch Release Point Adjustment .....	5C-8
<b>SPECIAL TOOLS</b> .....	5C-2	Air Bleeding .....	5C-8
Special Tools Table .....	5C-2	Pressure Plate and Clutch Disc .....	5C-8
<b>DIAGNOSIS</b> .....	5C-2	Clutch Master Cylinder Assembly .....	5C-10
Clutch Operation .....	5C-2	Concentric Slave Cylinder .....	5C-12
<b>COMPONENT LOCATOR</b> .....	5C-4	<b>GENERAL DESCRIPTION AND SYSTEM</b>	
Clutch Components .....	5C-4	<b>OPERATION</b> .....	5C-14
<b>MAINTENANCE AND REPAIR</b> .....	5C-6	Driving Members .....	5C-14
<b>ON-VEHICLE SERVICE</b> .....	5C-6	Driven Members .....	5C-14
Clutch Pedal .....	5C-6	Operating Members .....	5C-14

### SPECIFICATIONS

#### FASTENER TIGHTENING SPECIFICATIONS

Application	N•m	Lb-Ft	Lb-In
Clutch Master Cylinder nuts	22	16	–
Concentric Slave Cylinder Retaining Bolts	7	–	62
Concentric Slave Cylinder-to-Clutch Oil Pipe Screw	15	11	–
Pressure Plate-to-Flywheel Bolts	15	11	–

## SPECIAL TOOLS

### SPECIAL TOOLS TABLE

 <p style="text-align: center;">J42474</p>	<p style="text-align: center;">J-42474 Clutch Arbor</p>
---	---

## DIAGNOSIS

### CLUTCH OPERATION

#### Intermittent Clutch Operation

Checks	Action
Check for the driver improperly operating the vehicle.	Correct the driver's operation of the vehicle as necessary.
Check for the improper clutch pedal play.	Adjust the clutch pedal play.
Check for the insufficient oil or the leak at oil pressure line.	Repair the leak or add the oil.
Check for a warped or worn clutch disc.	Replace the clutch disc.
Check for worn splines on the input shaft.	Repair or Replace the splines on the input shaft.
Check for a weak diaphragm spring.	Replace the pressure plate.

#### Clutch Slipping

Checks	Action
Check for a stuck concentric slave cylinder.	Replace the concentric slave cylinder.
Check for improper return of clutch oil.	Perform the air bleeding.
Check for a worn clutch disc or oil contamination.	Replace the clutch disc.
Check for a warped pressure plate.	Replace the pressure plate.

### Clutch Vibration

Checks	Action
Check for a contaminated or warped flywheel.	Repair or replace the flywheel.
Check for a weak diaphragm spring.	Replace the pressure plate.
Check for a oily contamination of clutch disc.	Replace the clutch disc.
Check for worn splines on the input shaft.	Replace the splines on the input shaft.
Check for a warped pressure plate or flywheel.	Replace the pressure plate or flywheel.

### Hard Pedal Effort

Checks	Action
Check for bad lubrication of clutch pedal shaft.	Apply the grease or repair it.
Check for a clogged pipe.	Inspect or replace the clogged pipe.
Check for a stuck concentric slave cylinder.	Replace the concentric slave cylinder.

### Noise in Clutch Pedal

Checks	Action
Check for insufficient lubrication of clutch pedal bushing.	Lubricate the clutch pedal bushing.
Check for interference of clutch pedal return spring.	Remove and reinstall the clutch pedal return spring.

# COMPONENT LOCATOR

## CLUTCH COMPONENTS

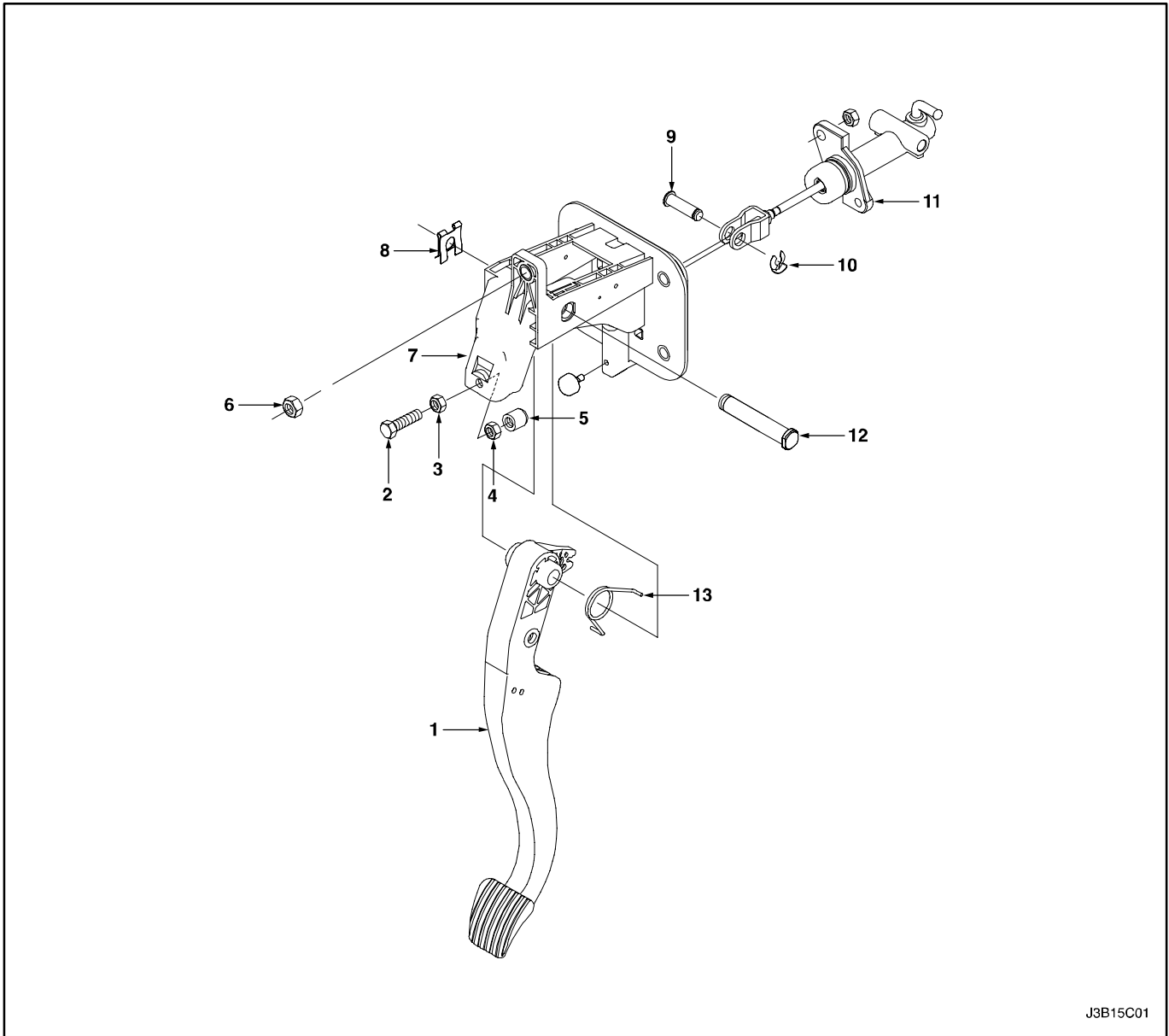

J3B15C01

1. Clutch Pedal
2. Bolt
3. Nut
4. Lock Nut
5. Clutch Pedal Buffer
6. Nut
7. Clutch Pedal Brace

8. E-Ring
9. Pin
10. E-Ring
11. Clutch Master Cylinder
12. Clutch Pedal Shaft
13. Turn-over Spring

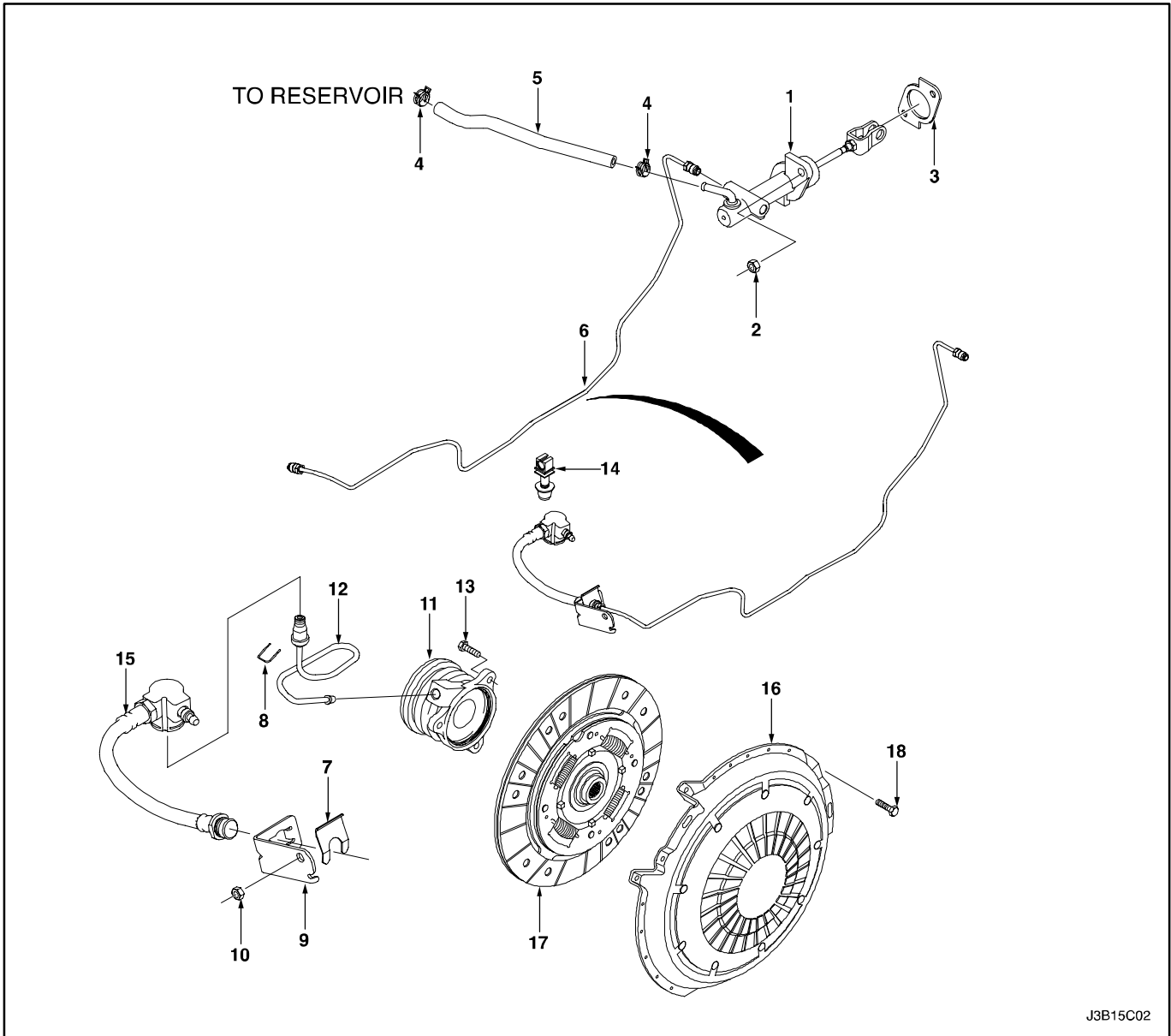

J3B15C02

- |                                |                                    |
|--------------------------------|------------------------------------|
| 1. Clutch Master Cylinder      | 10. Bolt                           |
| 2. Nut                         | 11. Concentric Slave Cylinder      |
| 3. Gasket                      | 12. Concentric Slave Cylinder Pipe |
| 4. Clip                        | 13. Bolt                           |
| 5. Reservoir Hose              | 14. Clip                           |
| 6. Clutch Master Cylinder Pipe | 15. Hose                           |
| 7. Clip                        | 16. Pressure Plate                 |
| 8. Clip                        | 17. Clutch Disc                    |
| 9. Bracket                     | 18. Bolt                           |

# MAINTENANCE AND REPAIR

## ON-VEHICLE SERVICE

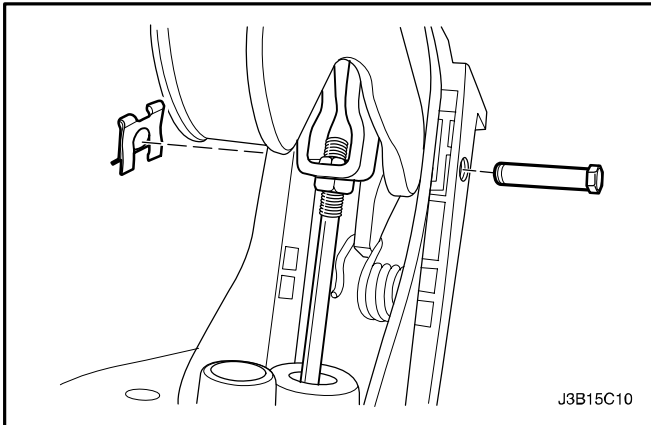

### CLUTCH PEDAL

#### Removal Procedure

1. Disconnect the negative battery cable.
2. Disconnect the return spring from the clutch pedal.
3. Remove the clip and the pedal mounting shaft.

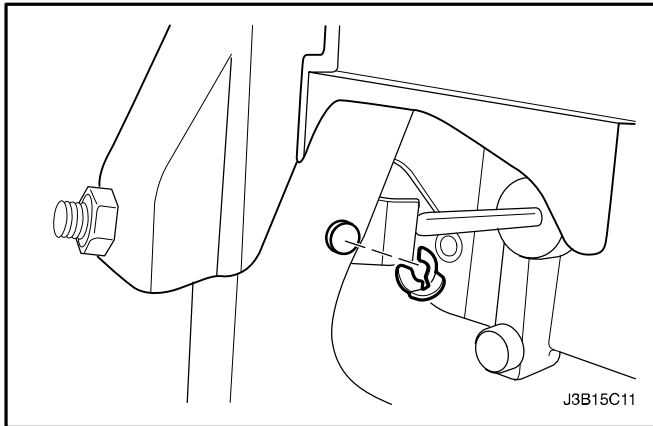

4. Remove the locking clip and push rod fixing pin.
5. Remove the push rod from the clutch pedal.
6. Remove the clutch pedal.

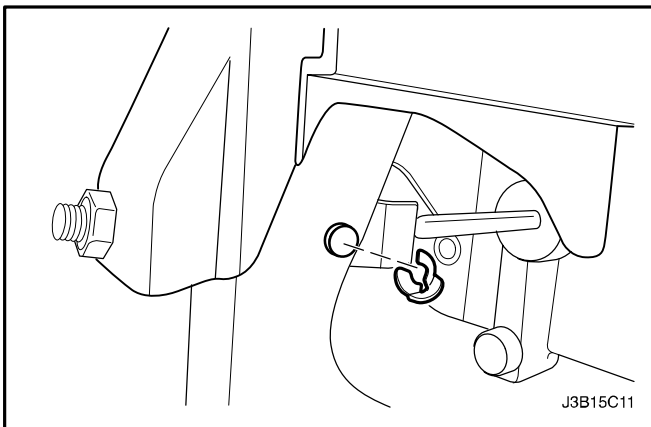

#### Installation Procedure

1. Install the clutch pedal.
2. Coat the push rod with multi-purpose grease.
3. Install the push rod to the clutch pedal.
4. Install the locking clip and push rod fixing pin.

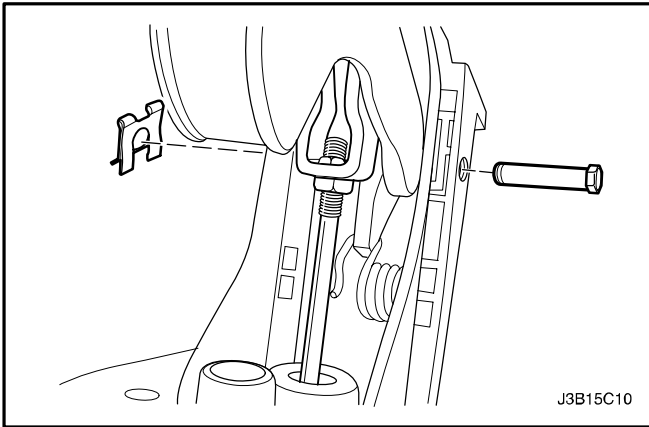

5. Coat the pedal mounting shaft with multi-purpose grease.
6. Install the clip and the pedal mounting shaft.
7. Connect the return spring to the clutch pedal.
8. Adjust the clutch pedal play. Refer to "Clutch Pedal Adjustment" in this section.
9. Connect the negative battery cable.

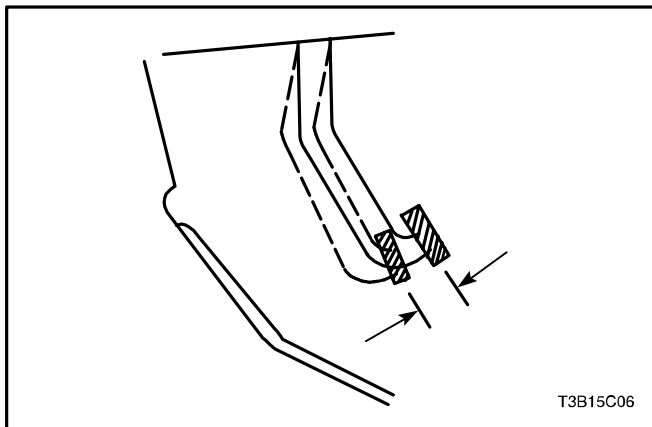

## CLUTCH PEDAL ADJUSTMENT

### Adjustment Procedure

1. Determine the clutch pedal play. Depress the clutch pedal lightly with your hand and measure the distance when you feel resistance.

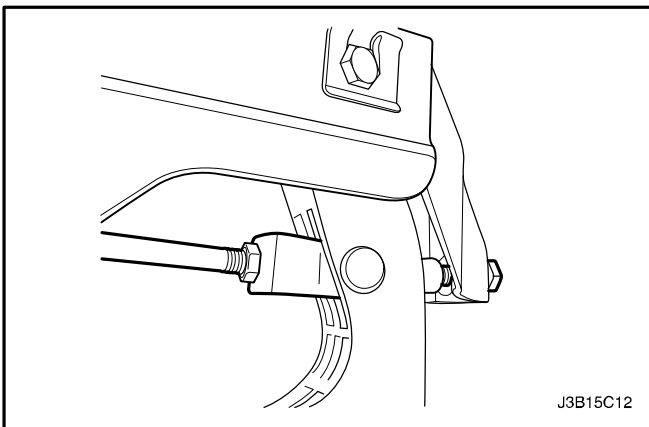

2. Adjust the clutch pedal play. Loosen the locknut and turn the pushrod. Clutch pedal play should measure 6 to 12 mm (0.2 to 0.5 inch). Tighten the locknut after adjustment.

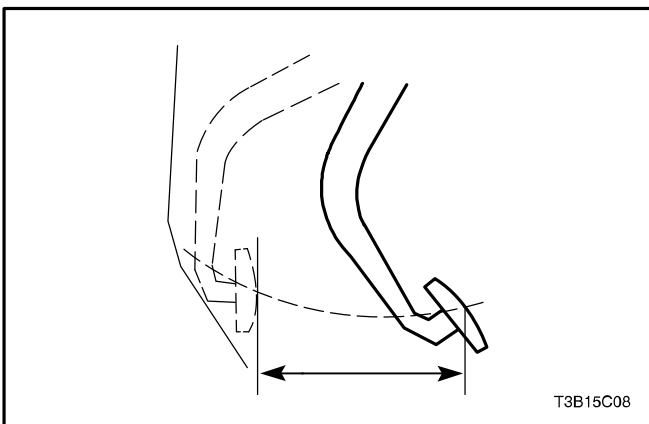

3. Measure the clutch pedal travel. Press the clutch pedal all the way to the floor. Measure from the starting position to the ending position.
4. Adjust the clutch pedal travel. Loosen the locknut and turn the bolt. Clutch pedal travel should measure 130 to 140 mm (5.1 to 5.5 inches). Tighten the locknut after adjustment.

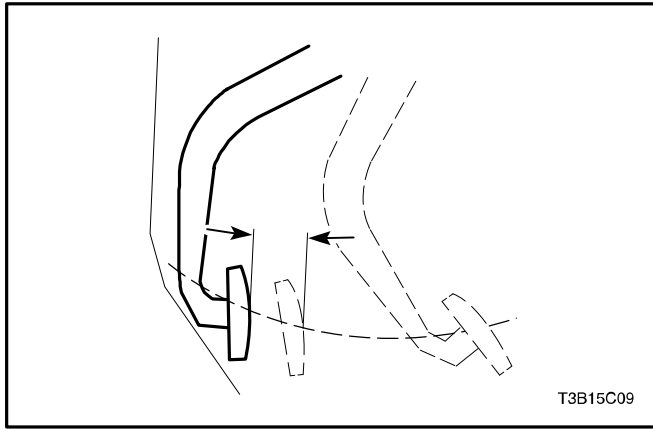

## CLUTCH RELEASE POINT ADJUSTMENT

### Adjustment Procedure

1. Apply the parking brake.
2. Run the engine at idle speed.
3. While you move the shift lever into the reverse position, depress the clutch pedal slowly and measure the distance between the point when gear noise is not heard and the point the clutch pedal is completely depressed. The distance should be 30 to 40 mm (1.2 to 1.6 inches).
4. If the distance is not within the specified value, check the following:
  - Clutch pedal height
  - Clutch pedal play
  - Air in the system
  - Clutch cover and disc pressure plate

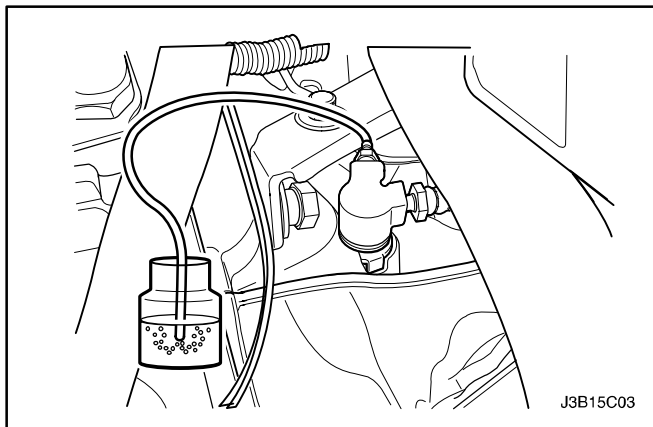

## AIR BLEEDING

Bleed the hydraulic system to remove the air which entered when the pipes were disconnected for repairs. The clutch/brake fluid in the clutch/brake reservoir must be maintained at the MIN level or higher during air bleeding.

1. Attach a vinyl hose to the bleeder plug. Place the other end of the vinyl tube in a glass container half-filled with brake fluid.
2. Slowly pump the clutch pedal several times.
3. While you press the clutch pedal, loosen the bleeder screw until the fluid starts to run out. Close the bleeder screw.
4. Repeat Step 3 until there are no air bubbles in the fluid.
5. Fill the reservoir with brake fluid up to the proper level.

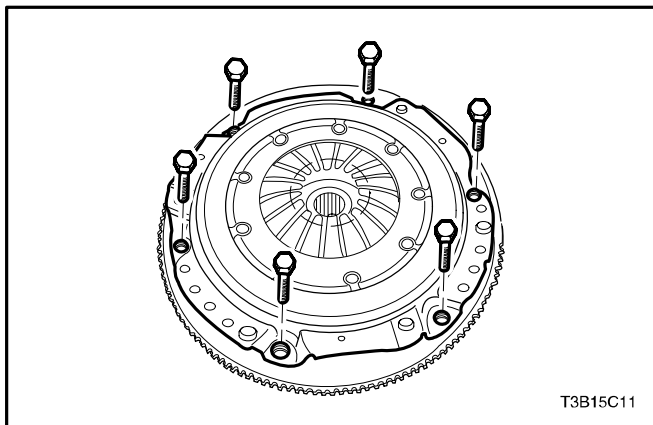

## PRESSURE PLATE AND CLUTCH DISC

### Removal Procedure

1. Disconnect the negative battery cable.
2. Remove the transaxle from the vehicle. Refer to *Section 5B, Five-Speed Manual Transaxle*.
3. Remove the pressure plate bolts and the pressure plate.

**Important :** Support the pressure plate when you remove the last bolt.

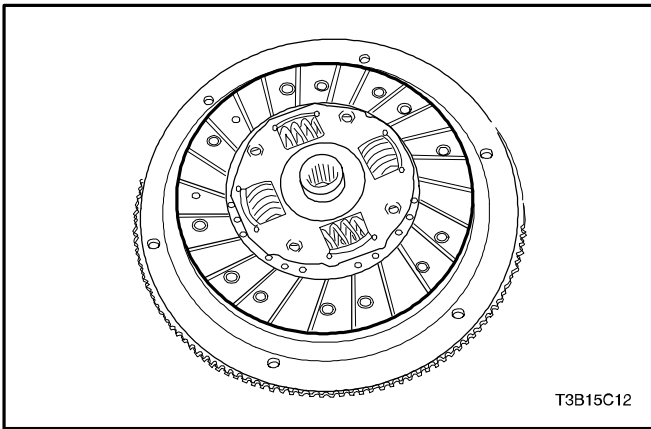

4. Remove the clutch disc from the flywheel.

### Inspection Procedure – Clutch Disc

#### 1. Visual Inspection

- Inspect the worn or oily contamination on the clutch surface.
- Inspect the damaged or weakened torsion spring.
- Inspect the a warped or bent clutch disc. After inspection, replace new clutch disc, if necessary.

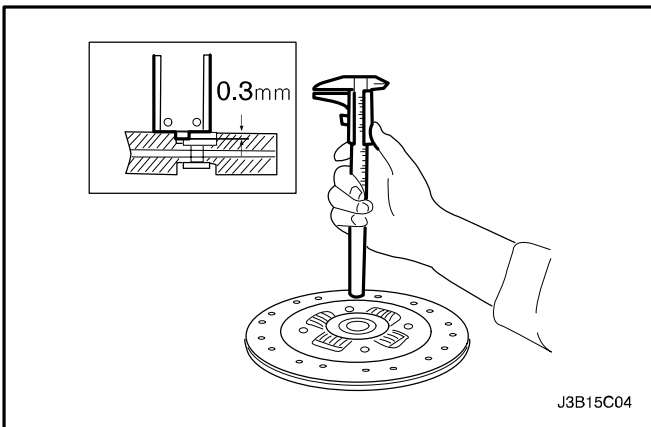

#### 2. Clutch Disc Inspection

- Measure the rivet head depth from the clutch disc surface.
- Replace the clutch disc if the measured value is below the limit.
- Rivet Head Depth (Limit) : 0.3 mm (0.012 in)

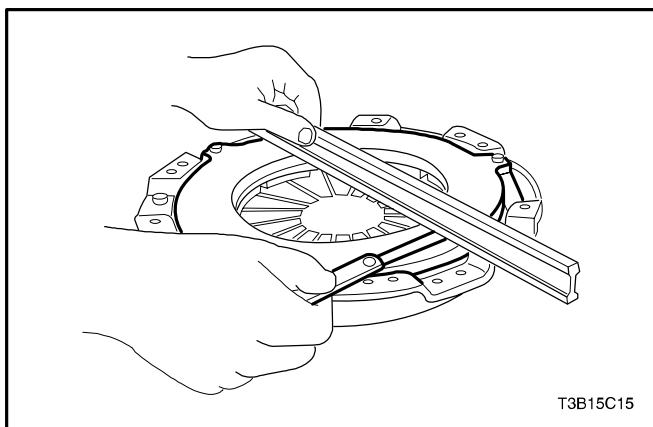

### Inspection Procedure – Pressure Plate

1. Check for a worn diaphragm spring finger.
2. Check for a worn or cracked pressure plate surface.
3. Check for the polluted face by the oil. After inspection, replace the pressure plate if necessary.

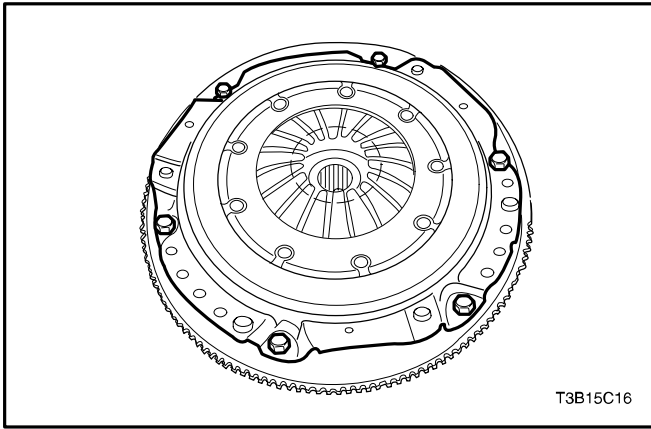

### Installation Procedure

1. Coat the spline on the clutch disc with multi-purpose grease.
2. Align the pressure plate and the clutch disc onto the flywheel using the clutch arbor J-42474.
3. Install the pressure plate bolts.

### Tighten

Tighten the bolts to 15 N•m (11 lb-ft).

4. Remove the clutch arbor J-42474.
5. Install the transaxle into the vehicle. Refer to Section 5B, Five-Speed Manual Transaxle.
6. Connect the negative battery cable.

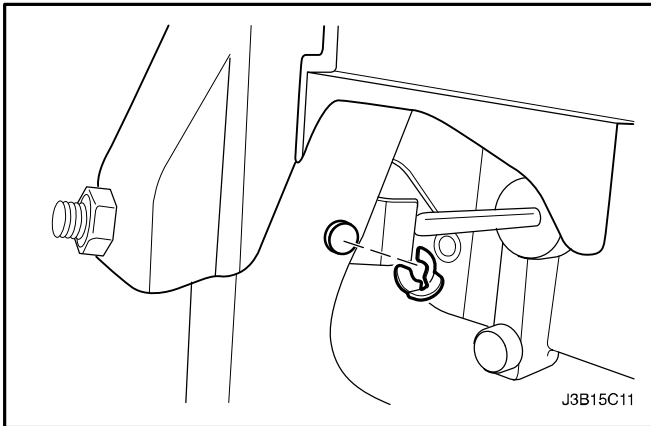

## CLUTCH MASTER CYLINDER ASSEMBLY

### Removal Procedure

Before disconnecting the reservoir tank hose, remove the clutch/brake fluid from the reservoir tank.

1. Remove the locking clip.
2. Remove the push rod fixing pin and push rod.
3. Disconnect the hose clamp on the master cylinder.
4. Disconnect the master cylinder hose.

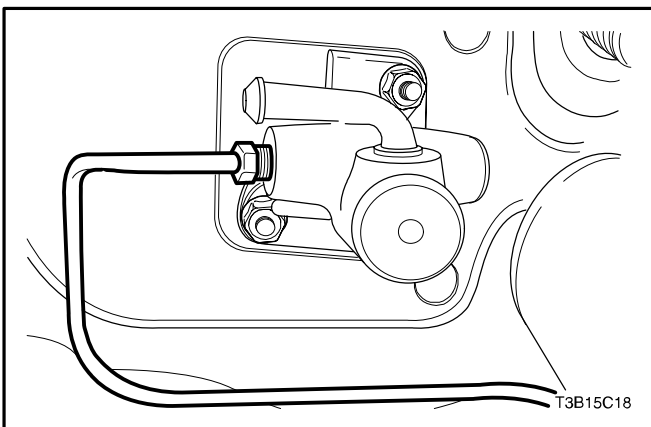
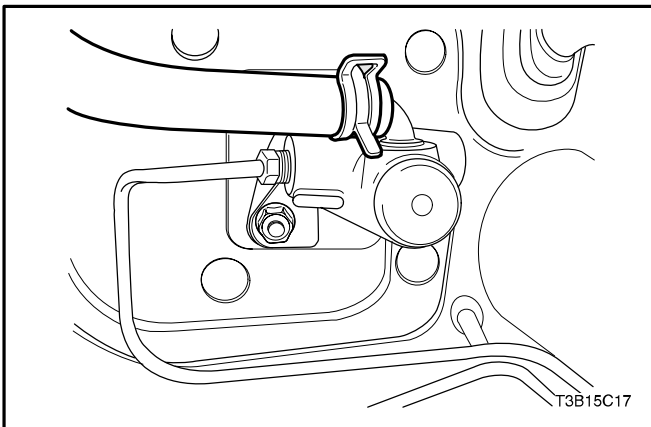

5. Remove the master cylinder pipe.

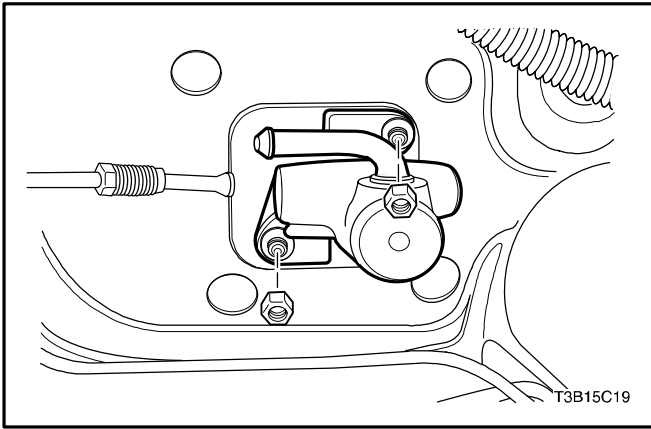

6. Remove the clutch master cylinder nuts.
7. Remove the clutch master cylinder.

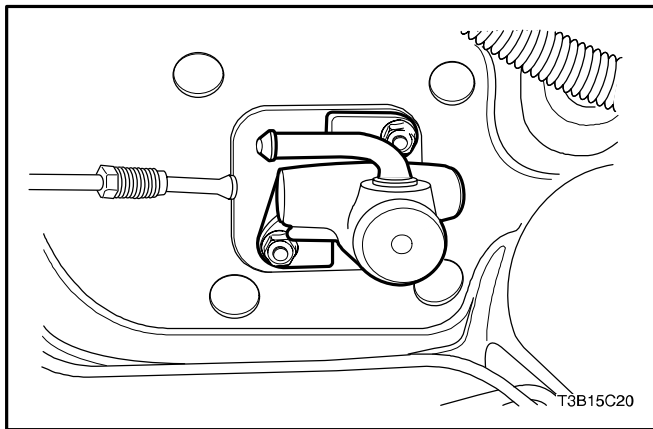

### Installation Procedure

1. Install the clutch master cylinder and clutch master cylinder nuts.

#### **Tighten**

Tighten the clutch master cylinder nuts to 22 N•m (16 lb–ft).

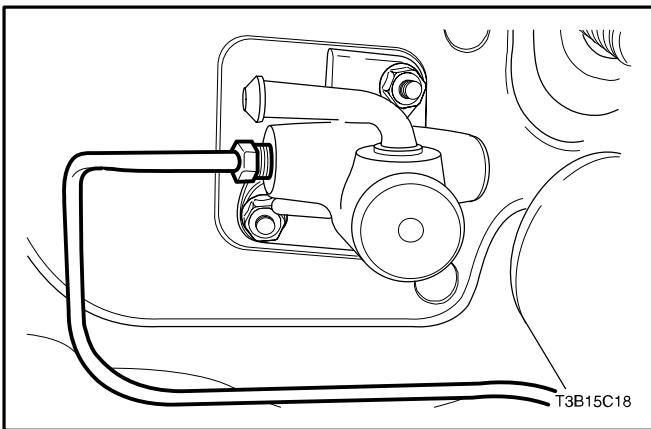

2. Install the master cylinder pipe.

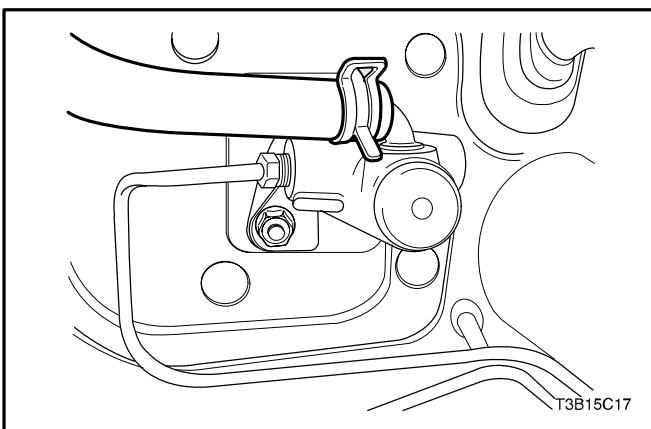

3. Connect the master cylinder hose.
4. Connect the hose clamp on the master cylinder.

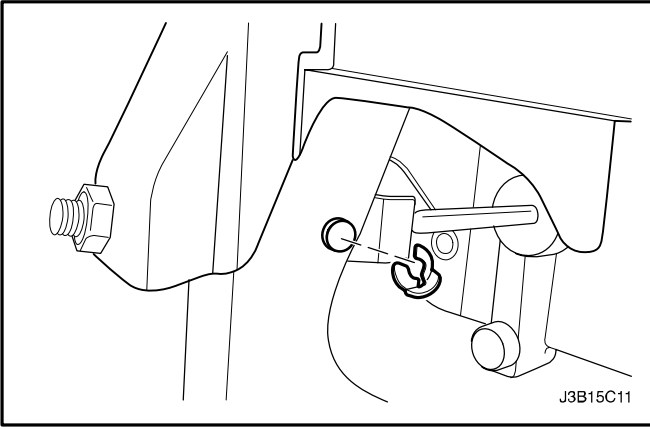

5. Install the push rod fixing pin and push rod.
6. Install the locking clip.
7. Bleed the air. Refer to "Air Bleeding" in this section.
8. Adjust the clutch pedal. Refer to "Clutch Pedal Adjustment" in this section.
9. Fill the reservoir with clutch/brake fluid up to the proper level.

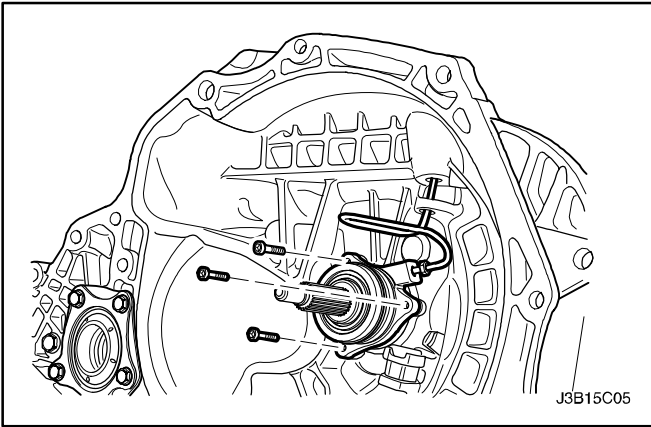

## CONCENTRIC SLAVE CYLINDER

### Removal Procedure

1. Remove the transaxle from the vehicle. Refer to *Section 5B, Five-Speed Manual Transaxle*.
2. Remove the concentric slave cylinder retaining bolts.
3. Disconnect the concentric slave cylinder pipe from the concentric slave cylinder.

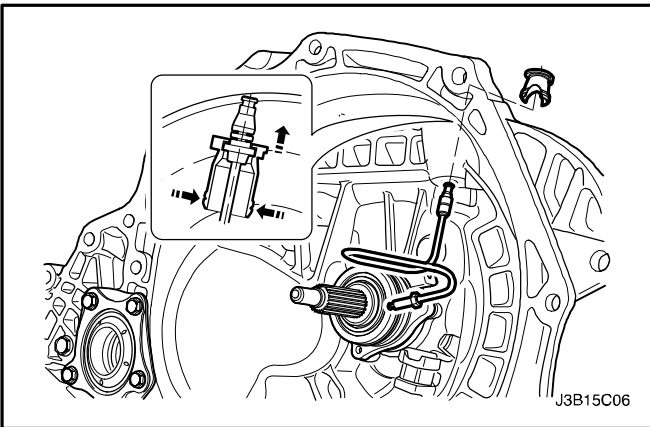

**Notice :** When removing the bushing, Make sure not to remove it with excessive force.

4. Remove the bushing from the concentric slave cylinder pipe in the transaxle housing.
5. Remove the concentric slave cylinder pipe.

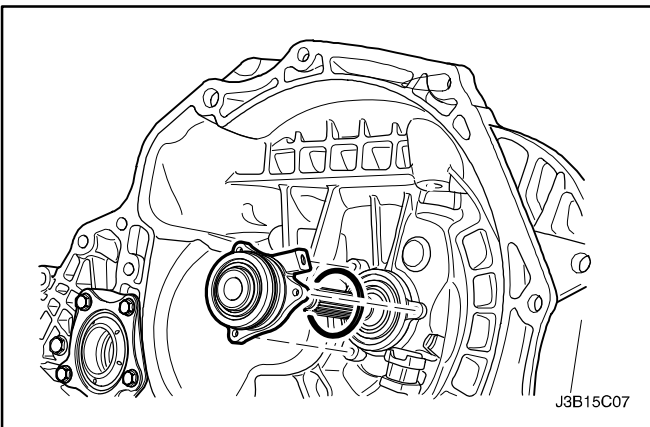

**Notice :** For removal or installation, Make sure not to separate oil seal fixing spring from the back side of the concentric slave cylinder.

6. Remove the O-ring and the concentric slave cylinder.

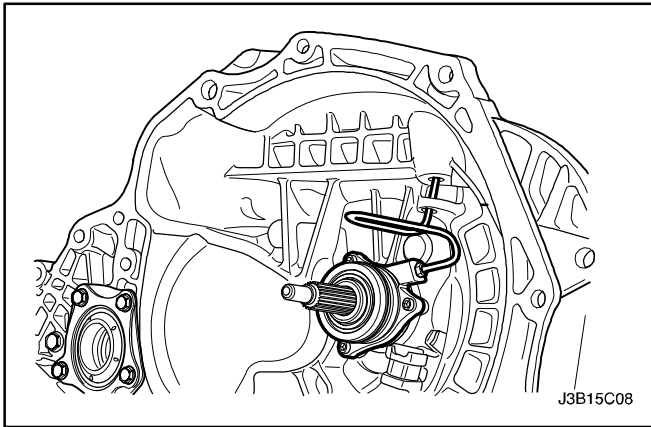

## Installation Procedure

1. Install the concentric slave cylinder and the pipe.
2. After installing the pipe screw provisionally, tighten the concentric slave cylinder retaining bolts.

### Tighten

Tighten the concentric slave cylinder retaining bolts to 7 N•m ( 62 lb-in).

3. Tighten the pipe screw.

### Tighten

Tighten the pipe screw to 15 N•m (11 lb-ft).

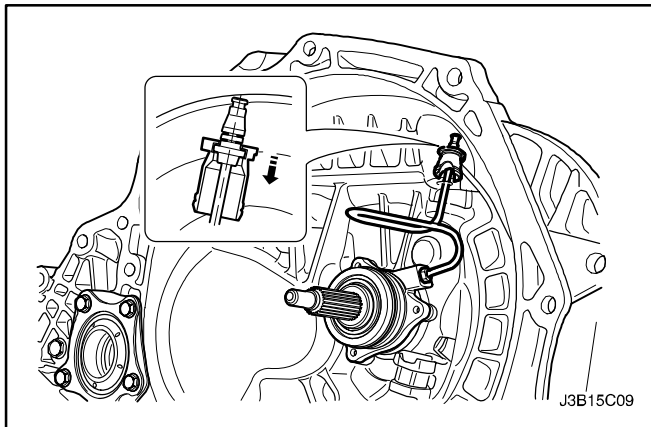

4. Install the bushing onto the transaxle housing.
5. Connect the pipe with bushing.
6. Install the transaxle into the vehicle. Refer to Section 5B, Five-Speed Manual Transaxle.

## **GENERAL DESCRIPTION AND SYSTEM OPERATION**

### **DRIVING MEMBERS**

The driving members consist of two flat surfaces machined to a smooth finish. One of these is the rear face of the engine flywheel and the other is the pressure plate. The pressure plate is fitted into a steel cover which is bolted the flywheel.

### **DRIVEN MEMBERS**

The driven member is the clutch disc with a splined hub.

The splined hub is free to slide lengthwise along the splines of the input shaft and drives the input shaft through these same splines.

The driving and driven members are held in contact by spring pressure. This pressure is exerted by a diaphragm spring in the pressure plate assembly.

### **OPERATING MEMBERS**

The clutch release system consists of the clutch pedal, the clutch master cylinder, and concentric slave cylinder.

Unlike the former system to release the clutch by the release lever and release fork, the concentric slave cylinder type makes the concentric slave cylinder directly perform the clutch release by the generated pressure through the clutch pedal operation.