

SECTION : 4E2

REAR DRUM BRAKES

TABLE OF CONTENTS

SPECIFICATIONS	4E2-1	Shoe and Lining	4E2-4
Fastener Tightening Specifications	4E2-1	Wheel Cylinder Assembly	4E2-7
DIAGNOSIS	4E2-1	Backing Plate	4E2-8
Lining Inspection	4E2-1	UNIT REPAIR	4E2-10
Drums	4E2-1	Wheel Cylinder	4E2-10
MAINTENANCE AND REPAIR	4E2-3	GENERAL DESCRIPTION AND SYSTEM	
ON-VEHICLE SERVICE	4E2-3	OPERATION	4E2-12
Brake Adjustment	4E2-3	Drum Brakes	4E2-12

SPECIFICATIONS

FASTENER TIGHTENING SPECIFICATIONS

Application	N•m	Lb-Ft	Lb-In
Brake Line	16	12	–
Brake Wheel Hub/Backing Plate-to-Rear Axle Nuts	28	21	–
Wheel Cylinder-to-Backing Plate Bolt	8	–	71

DIAGNOSIS

LINING INSPECTION

1. Raise and suitably support the vehicle.
2. Remove the wheel. Refer to *Section 2E, Tires and Wheels*.
3. Release the parking brake.
4. Remove the drum. Refer to "Drum" in this section.
5. Measure the lining thickness. The minimum lining thickness is 0.5 mm (0.02 inch).

CAUTION : To avoid injury when servicing brake parts, do not create dust by grinding or sanding the brake linings or by cleaning the wheel brake parts with a dry brush or with compressed air.

Important : Replace the shoe and lining assembly in axle sets only.

6. Install the drum, if removed. Refer to "One-Piece Drum" or "Two-Piece Drum" in this section.
7. Install the wheel, if removed. Refer to *Section 2E, Tires and Wheels*.
8. Lower the vehicle.

DRUMS

Whenever brake drums are removed, they should be thoroughly cleaned and inspected to see if the drums are cracked, scored, deeply grooved, or beyond the specified out-of-round limit.

- A cracked drum is unsafe for further service and must be replaced. Do not attempt to weld a cracked drum. Smooth out any slight scores.
- Heavy or extensive scoring will cause excessive brake lining wear and may require refinishing the drum braking surface.
- If the brake linings are slightly worn but are still reusable and the drum is grooved, polish the drum with a fine emery cloth but do not refinish it. Eliminating all grooves in the drum and smoothing the ridges on the lining would remove too much metal and lining. If left alone, the grooves and ridges match, and satisfactory service can be obtained. If the brake linings need to be replaced, refinish a grooved drum. A grooved drum, used with a new

4E2 – 2 REAR DRUM BRAKES

lining, will not only wear the lining, but also will make it difficult, if not impossible, to obtain proper brake performance.

- An out-of-round drum makes accurate brake shoe adjustment impossible and is likely to cause excessive wear of other parts of the brake mechanism. An out-of-round drum can also cause severe and irregular tire tread wear, as well as a pulsating brake pedal.

- The extent to which a drum is worn or out of round can be measured accurately with an inside micrometer fitted with the proper extension rods. When measuring a drum for wear or the extent to which it is out of round, take measurements from the inside edge to the outside edge of the machined surface at 90-degree intervals around the circumference of the drum. When the drum exceeds the specified out-of-round limit, refinish the drum.

MAINTENANCE AND REPAIR

ON-VEHICLE SERVICE

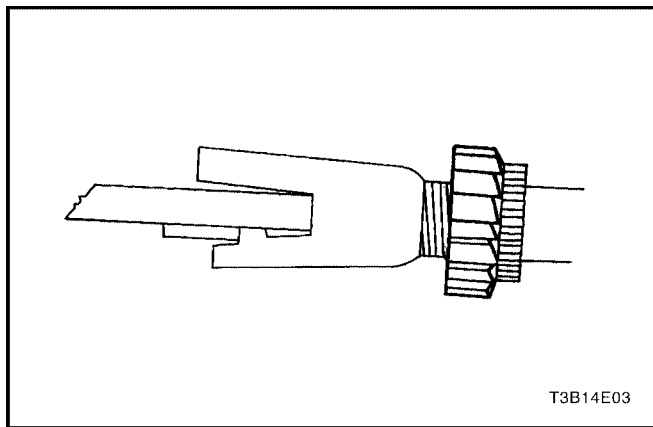
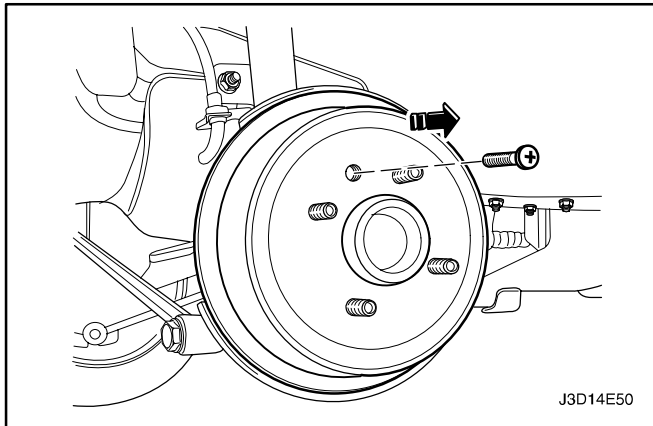
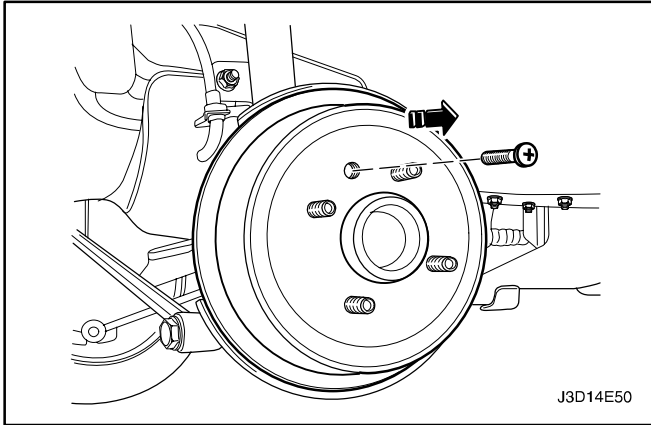

BRAKE ADJUSTMENT

Removal Procedure

1. Release the parking brake.
2. Operate the brake at least 10 times until the jumping of the adjustment spring on the adjustment nut can no longer be heard on either brake drum.
3. Raise and suitably support the vehicle.
4. Remove the rear wheels. Refer to *Section 2E, Tires and Wheels*.
5. Remove the drum detent screw.
6. Remove the brake drum.
7. Using the rear brake adjuster nut, turn the adjuster assembly in until there is a sufficient amount of drag on the brake drum.
8. Make sure that the parking brake lever stops are against the edge of the shoe web. If they are not, loosen the parking brake cable at the equalizer. Refer to *Section 4G, Parking Brake*.

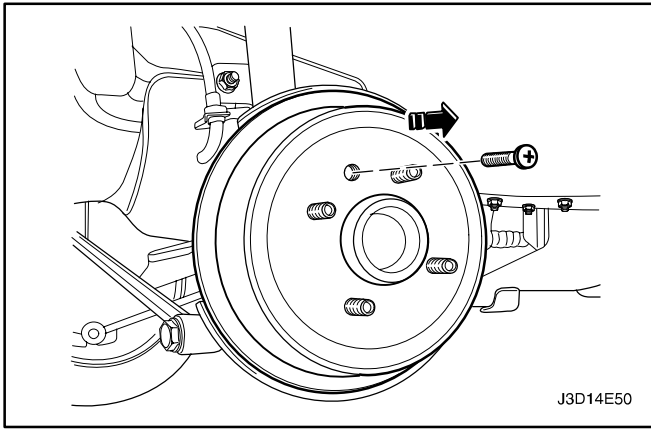

Installation Procedure

1. Position the rear brake drum. Fasten the drum detent screw.

Tighten

Tighten the drum detent screw to 4 N•m (35 lb-in).

2. Install the rear wheels. Refer to *Section 2E, Tires and Wheels*.

Important : The brake pedal must be operated more than 10 times. When the clicking can no longer be heard, the clearance between the brake shoe and drum is adjusted.

3. Apply the foot brake several times until the clicking of the adjustment actuator can no longer be heard.
4. Adjust the parking brake. Refer to *Section 4G, Parking Brake*.

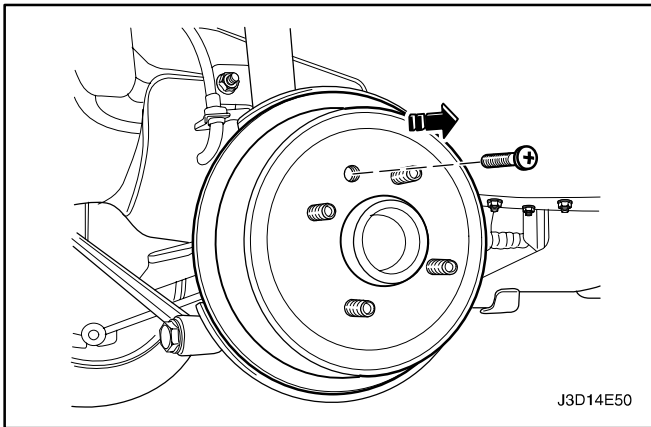

SHOE AND LINING

Removal Procedure

1. Raise and suitably support the vehicle.
2. Remove the rear wheels. Refer to *Section 2E, Tires and Wheels*.
3. Loosen the parking brake cable. Refer to *Section 4G, Parking Brake*.
4. Remove the brake drum.

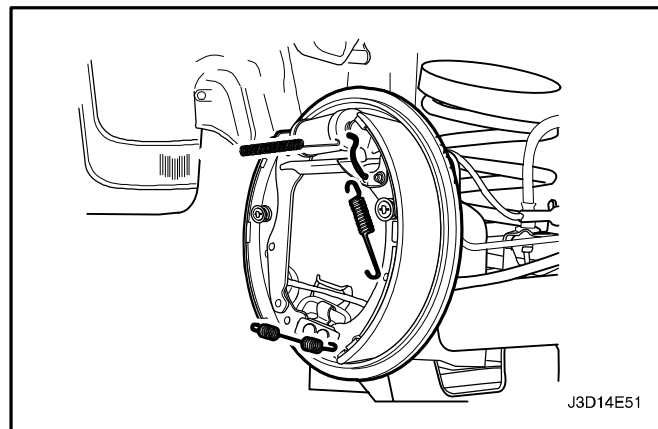

5. Loosen the leading shoe hold-down return spring.

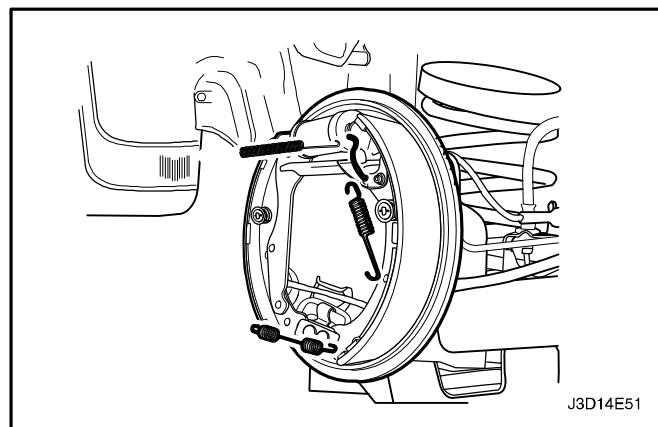

6. Disconnect the upper link of the connecting link spring of the leading shoe to relieve tension on the upper return spring.
7. Remove the upper return spring and the adjuster.

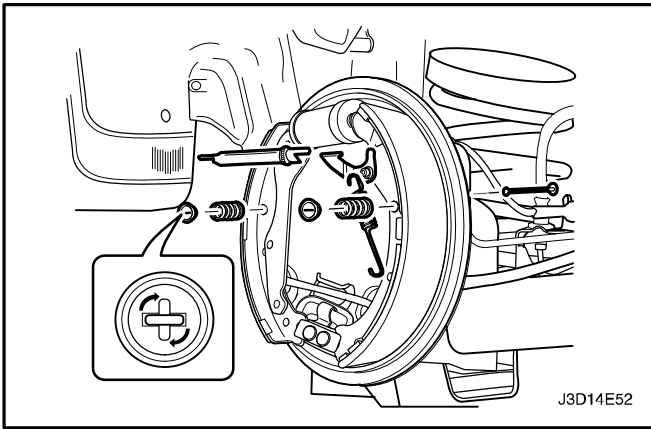

8. Unfasten the trailing shoe and lining assembly hold-down return spring.

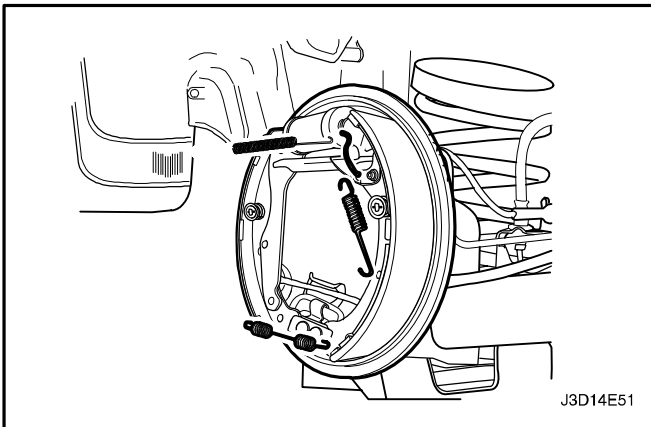

9. Disconnect the trailing shoe and lining assembly on the right side.
10. Detach the lower return spring.

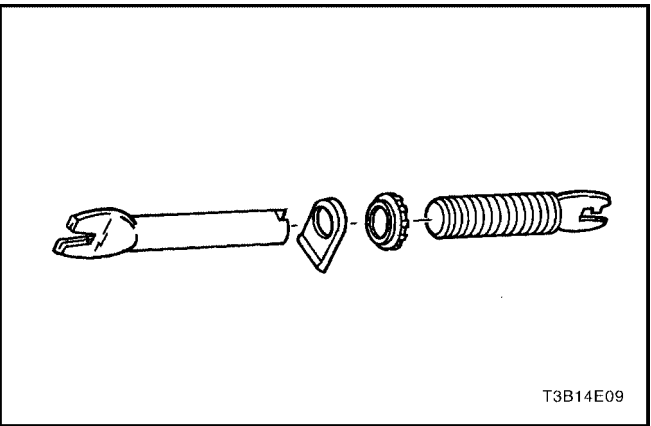

Installation Procedure

1. Measure the minimum brake lining thickness. Refer to "Lining Inspection" in this section.
2. Clean the adjuster assembly and apply grease.
Notice : If any parts are of questionable strength or quality because of heat discoloration, excessive stress, or wear, the shoes, the springs, or the adjuster assembly should be replaced.
3. Inspect the threads of the adjuster assembly for smooth rotation.

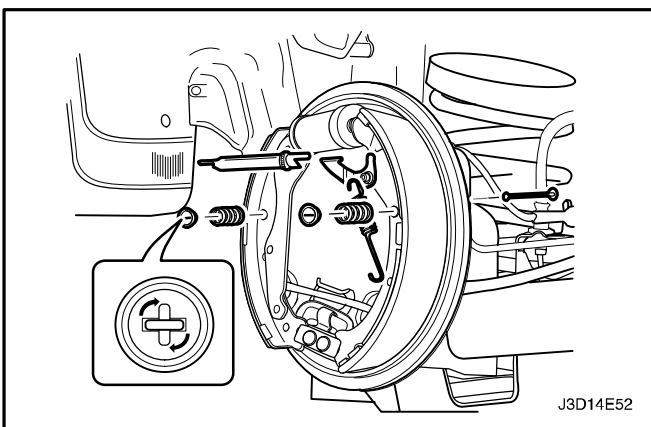

4. Install the trailing shoe and lining assembly with the hold-down spring, the washer, and the pin.
5. Make sure the parking brake cable is properly routed and attached to the shoe lever.
Notice : Do not overstretch the lower return spring.
6. Fasten the lower return spring on the shoe.

4E2 – 6 REAR DRUM BRAKES

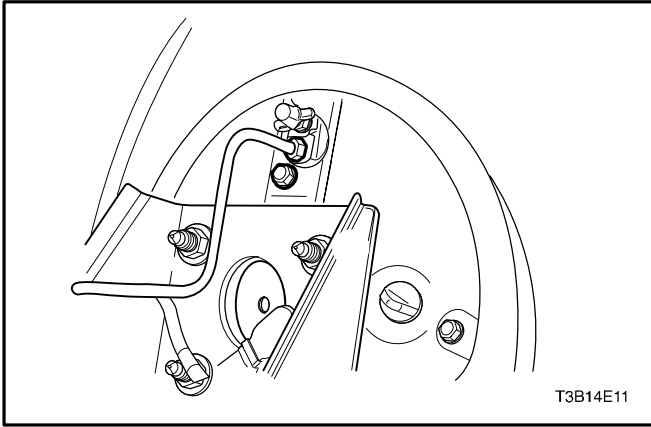

7. Position the leading shoe and the adjuster assembly against the backing plate.
8. Fasten the lower return spring to the leading shoe.

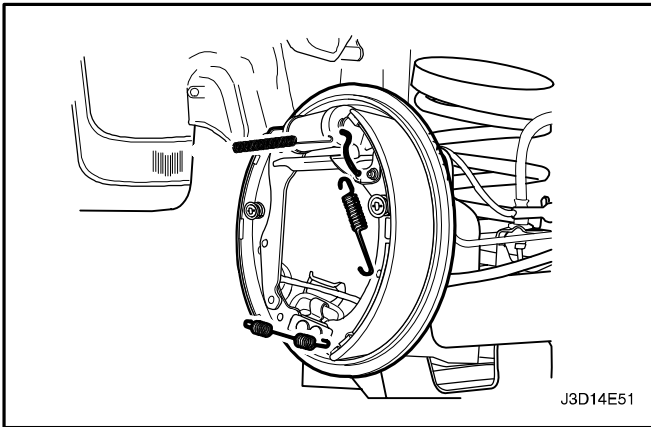

9. Install the adjuster assembly.
10. Turn the adjuster in as far as possible.
11. Position the spring clip toward the backing plate.
12. Install the leading shoe with the hold-down spring.

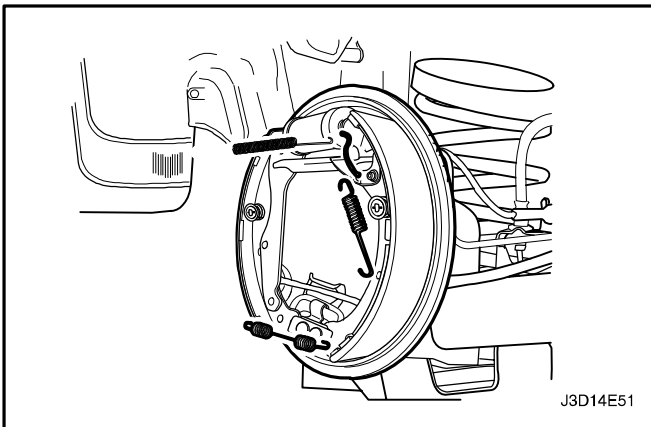

13. Attach the leading shoe upper link-spring connection, which applies tension to the upper return spring.

Notice : Do not overstretch the upper return spring.

14. Install the upper return spring from the spring connecting link to the brake shoe.

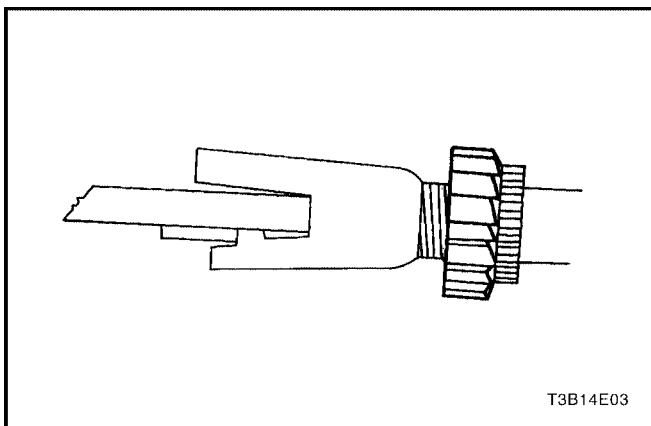

Notice : The nut must not lock firmly at the end of the adjustment assembly.

15. Before installing the brake drum, make sure the adjuster assembly nut is drawn all the way to the stop.

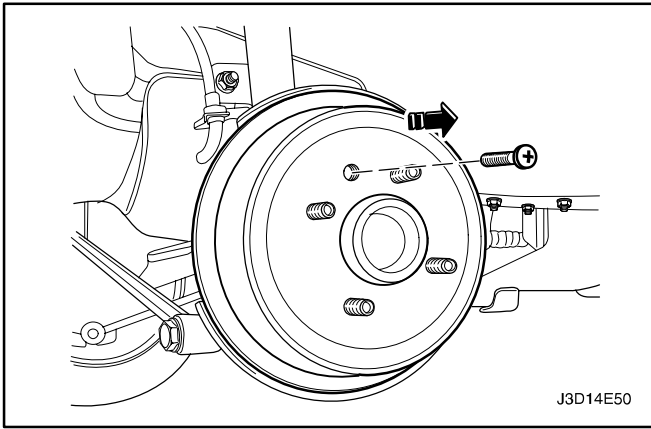

16. Install the brake drum and fasten it with the drum detent screw.

Tighten

Tighten the drum detent screw to 4 N•m (35 lb-in).

17. Install the rear wheels. Refer to *Section 2E, Tires and Wheels*.
18. Adjust the rear wheel brakes. Refer to "Brake Adjustment" in this section.
19. Adjust the parking brake. Refer to *Section 4G, Parking Brake*.
20. Lower the vehicle.

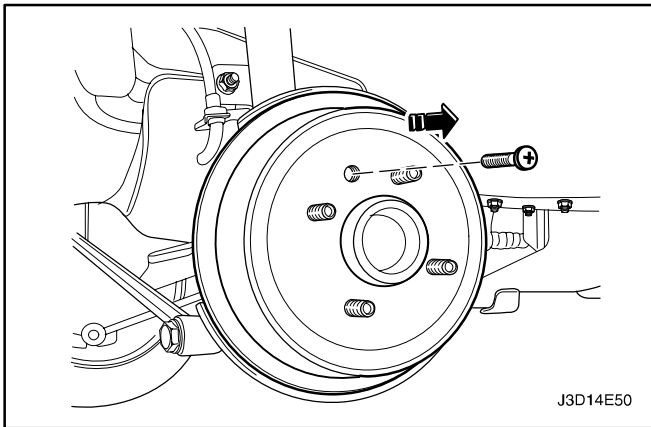

WHEEL CYLINDER ASSEMBLY

Removal Procedure

1. Raise and suitably support the vehicle.
2. Remove the rear wheels. Refer to *Section 2E, Tires and Wheels*.
3. Remove the brake drum.
4. Remove the shoe and lining. Refer to "Shoe and Lining" in this section.

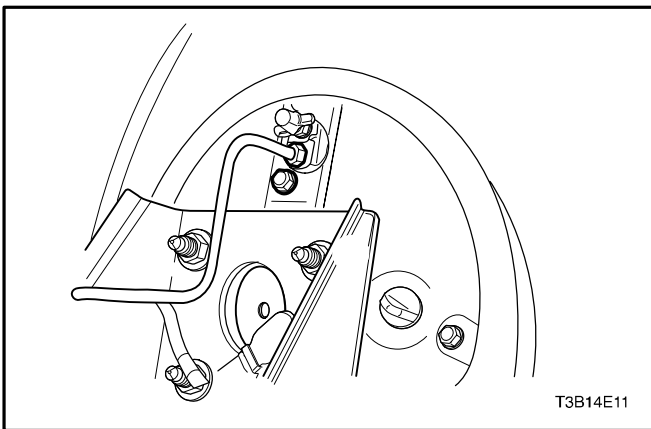

5. Clean dirt and foreign material from around the wheel cylinder brake line inlet, the pilot, and the bolt.
6. Disconnect the brake line from the wheel cylinder.
7. Plug the opening in the brake line to prevent fluid loss or contamination.

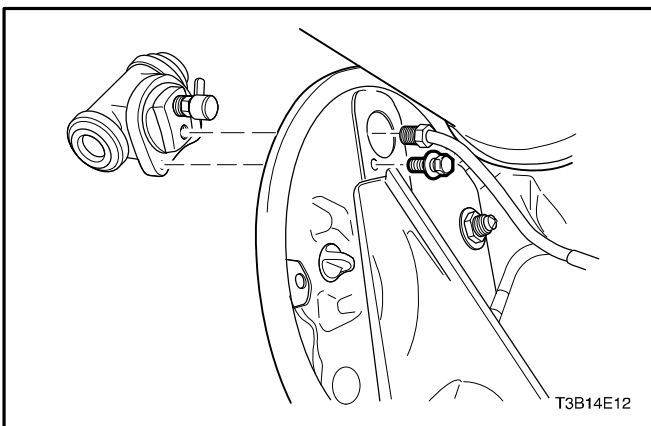

8. Remove the wheel cylinder-to-backing plate bolt.
9. Gently tap out the wheel cylinder from the backing plate, using care not to damage the bleeder valve or its cap.

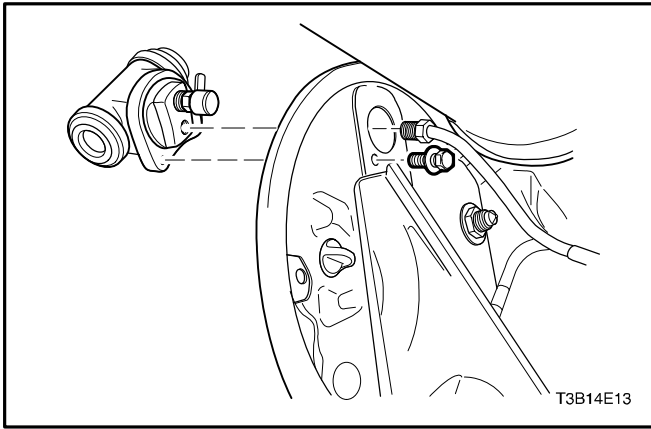

Installation Procedure

1. Install the wheel cylinder to the backing plate with the wheel cylinder bolt.

Tighten

Tighten the wheel cylinder-to-backing plate bolt to 8 N•m (71 lb-in).

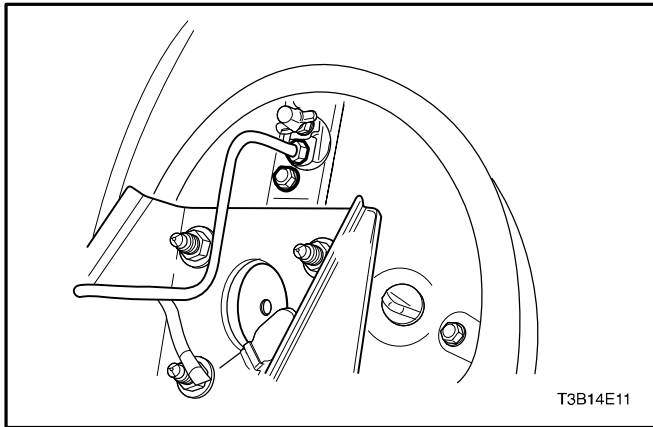

2. Connect the brake line to the wheel cylinder.

Tighten

Tighten the brake line to 16 N•m (12 lb-ft)

3. Install the shoe and lining, and the brake drum. Refer to "Shoe and Lining" in this section.
4. Bleed the brakes. Refer to *Section 4A, Hydraulic Brakes*.

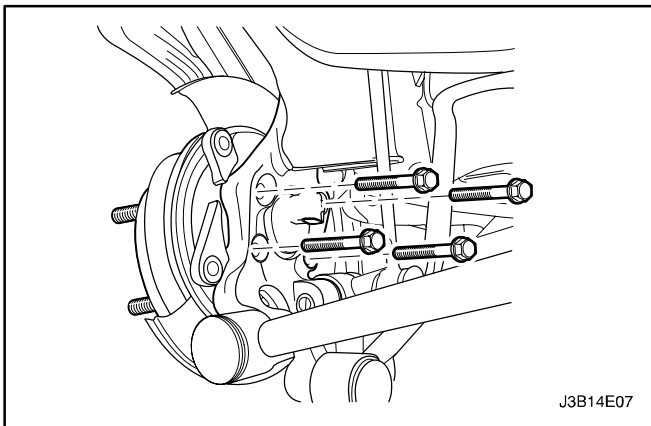

BACKING PLATE

Removal Procedure

1. Raise and suitably support the vehicle.
2. Remove the brake shoe components, including complete removal of the parking brake with the retainer. Refer to "Shoe and Lining" in this section and *Section 4A, Hydraulic Brakes*.
3. Remove the nuts that secure the wheel hub assembly to the backing plate.
4. Remove the brake line and plug the opening in the line to prevent fluid loss or contamination.
5. Remove the wheel cylinder assembly. Refer to "Wheel Cylinder Assembly" in this section.
6. Remove the wheel hub assembly.
7. In case of ABS brake, disconnect the cable that goes to the wheel speed sensor.
8. Separate the backing plate and the gasket.

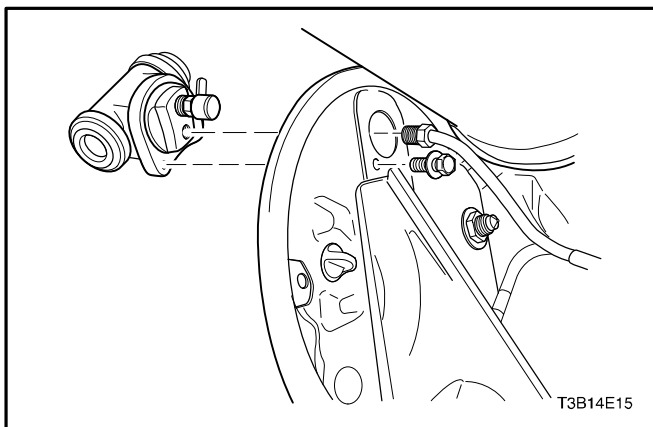

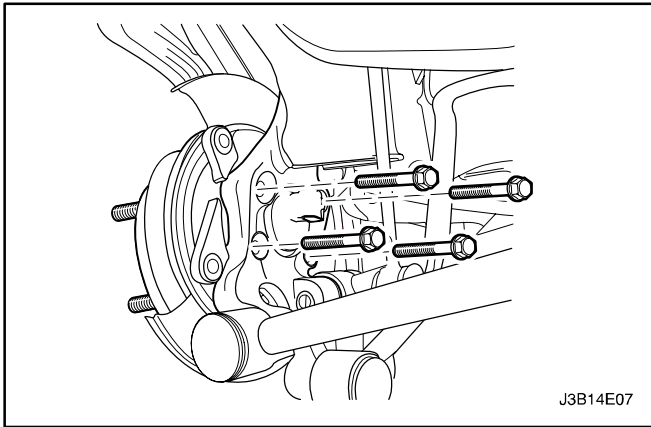

Installation Procedure

1. Install the hub with bolts.

Tighten

Tighten the hub bolts to 65 N•m (48 lb–ft).

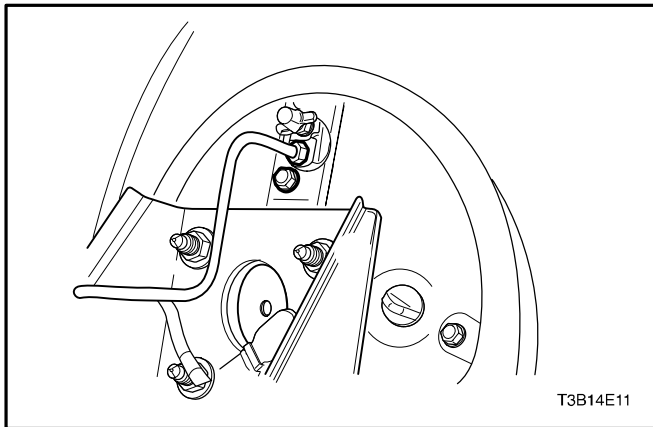

2. Install the brake wheel cylinder assembly to the backing plate. Refer to "Wheel Cylinder Assembly" in this section.

3. Connect the brake line.

Tighten

Tighten the brake line to 16 N•m (12 lb–ft).

4. Install the brake components. Refer to "Shoe and Lining" in this section.
5. Install the parking brake cable with the retainer by attaching the cable to the brake shoe lever. Refer to *Section 4G, Parking Brake*.
6. Bleed the brakes. Refer to *Section 4A, Hydraulic Brakes*.
7. Lower the vehicle.

UNIT REPAIR

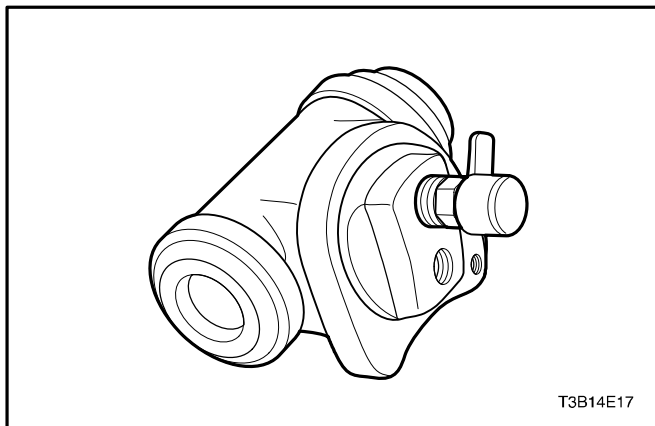
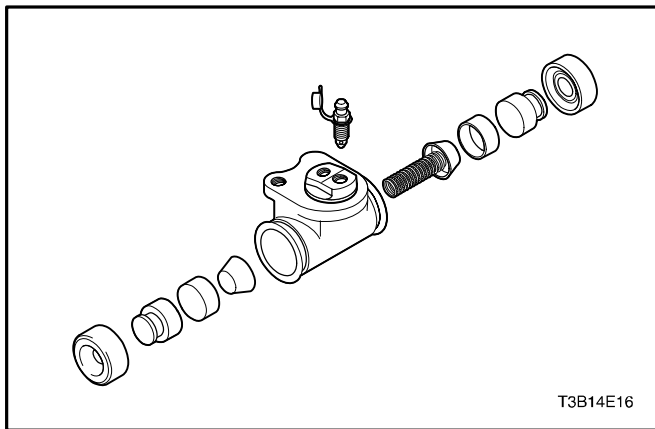
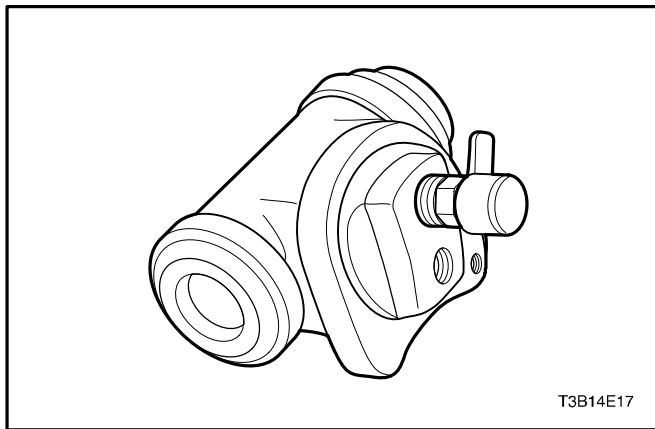
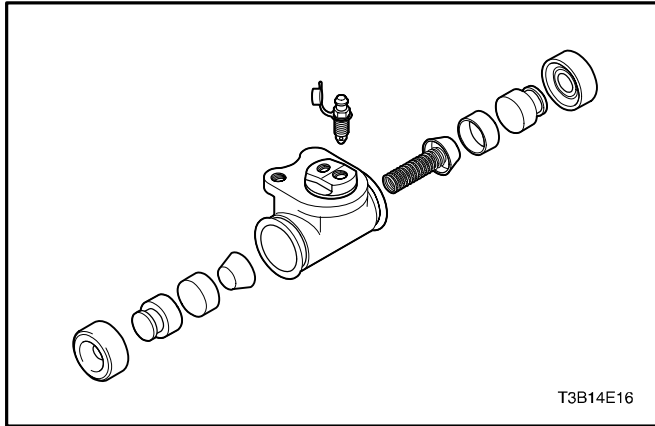

WHEEL CYLINDER

Disassembly Procedure

1. Remove the wheel cylinder assembly from the backing plate. Refer to "Wheel Cylinder Assembly" in this section.
2. Twist off the boots, the pistons, and the seals from each end of the wheel cylinder.
3. Remove the spring assembly.
4. Remove the bleeder cap and the bleeder valve.

Assembly Procedure

1. Inspect the wheel cylinder bore and the pistons for scoring, nicks, corrosion, and wear.
 2. Use a crocus cloth to polish out light corrosion in the wheel cylinder bore.
- Important :** If the bore will not clean up with a crocus cloth, replace the assembly.
3. Clean all the parts in clean denatured alcohol or brake fluid. Dry all the parts with unlubricated compressed air and lubricate the new seals, the pistons, and the wheel cylinder bore with clean brake fluid before assembly.
 4. Thinly coat all the parts except the dust caps with brake cylinder fluid.
 5. Fasten the bleeder valve and the cap to the wheel cylinder.

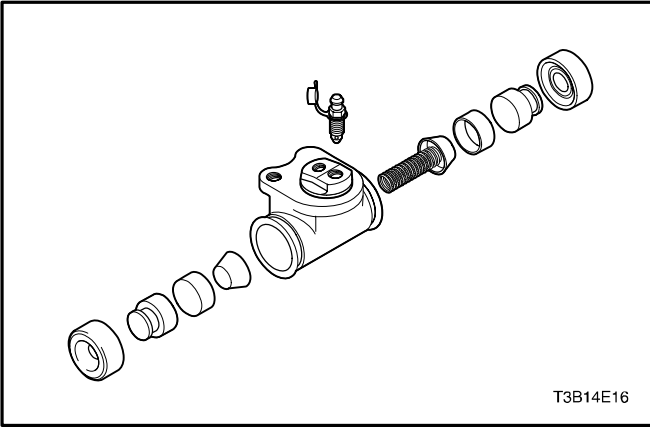

6. Attach to the wheel cylinder the spring assembly, followed by the pistons, the seals, and the boots.
7. Inspect the pistons for free movement.
8. Install the wheel cylinder assembly. Refer to "Wheel Cylinder Assembly" in this section.

GENERAL DESCRIPTION AND SYSTEM OPERATION

DRUM BRAKES

This drum brake assembly is a leading/trailing shoe design. Both brake shoes are held against the wheel cylinder pistons by the lower return spring and the fixed anchor plate near the lower return spring. When the brakes are applied, the wheel cylinder pistons move both shoes out to contact the drum. With forward wheel rotation, the forward brake shoe will wrap into the drum and become self-energized. With reverse wheel rotation, the rear brake shoe is self-energized. Force from the brake shoes is transferred to the anchor plate through the backing plate to the axle flange. Adjustment is automatic and occurs on any service brake application. Do not switch the position

of shoes that have been in service, as this may render the self-adjustment feature inoperative and result in increased pedal travel.

Notice : To avoid damaging the vehicle, observe the following directions:

- Replace all the components included in the repair kits used to service this drum brake.
- Do not use lubricated shop air on the brake parts, as damage to the rubber components may result.
- If any hydraulic component is removed or disconnected, it may be necessary to bleed all or part of the braking system.
- Replace the shoe and linings in axle sets only.
- The torque values specified are for dry, unlubricated fasteners.
- Perform service operations on a clean bench that is free from all mineral oil materials.